

E8 3/8" Plastic Pumps Specifications and Performance

SPECIFICATIONS

E8

FLOW RATE adjustable to.....0-6.8 gpm (26 lpm)

PORT SIZE

Inlet and Outlet 3/8" NPTF (BSP)

AIR INLET 0.25" NPT

AIR EXHAUST 0.25" NPT

SUCTION LIFT (dry)11' (3.4 m)

Teflon® (dry)11' (3.4 m)

MAX. PARTICLE SIZE (Dia.) 0.10" (2.5 mm)

SHIPPING WEIGHT

Polypropylene 3.0 lbs (1.4 kg)

Kynar 3.0 lbs (1.4 kg)

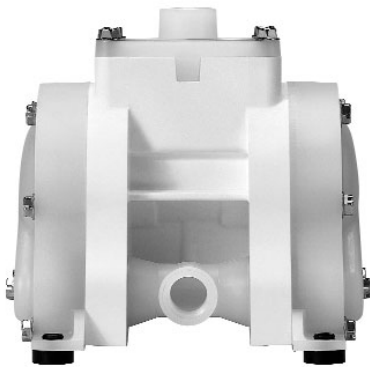

PERFORMANCE

Determined by actual flow meter tests.

E8

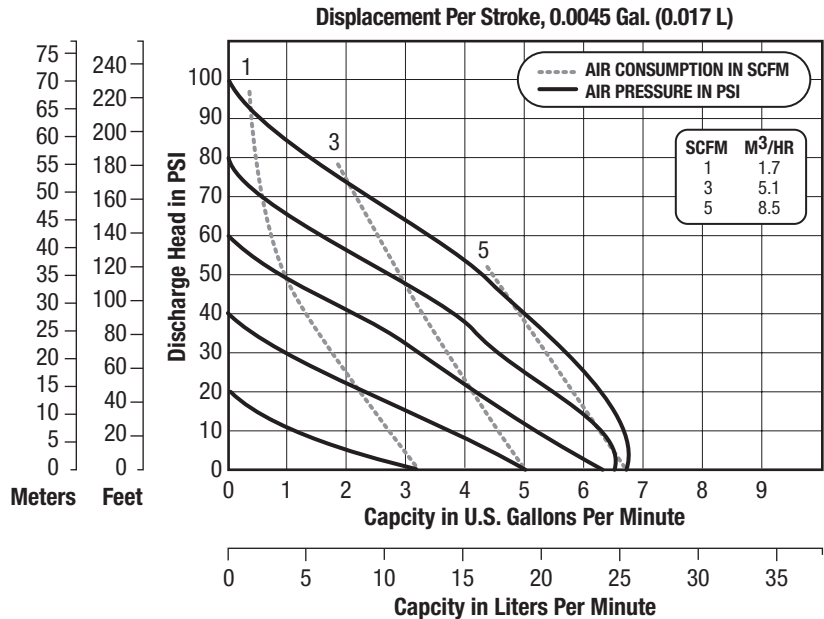

CAUTION: Do not exceed 100 psig (6.8 bars) air supply or liquid pressure.

CAUTION: Plastic pumps and components are not UV stabilized. Ultraviolet radiation can damage these parts and negatively affect material properties. Do not expose to UV light for extended periods of time.

DIMENSIONS

Consult factory for certified drawings.

E8

