

E5 1/2" Bolted Metallic Pumps Specifications and Performance

SPECIFICATIONS

E5

FLOW RATE (Adjustable) 0-14 gpm (53 lpm)

PORT SIZE

Inlet & Outlet 0.50" NPT

AIR INLET 0.375" NPT

AIR EXHAUST 0.375" NPT

SUCTION LIFT.. 15' Dry/25' Wet (6.096m/7.62m)

Teflon® 5' Dry/10' Wet (1.52m/3.048m)

MAX. PARTICLE SIZE (Dia.) 0.0625" (1.6mm)

SHIPPING WEIGHTS

Stainless Steel 18 lbs (8.17 kg)

Hastelloy C 18 lbs (8.17 kg)

Aluminum 15 lbs (6.8 kg)



PERFORMANCE

Determined by actual flow meter tests.

E5

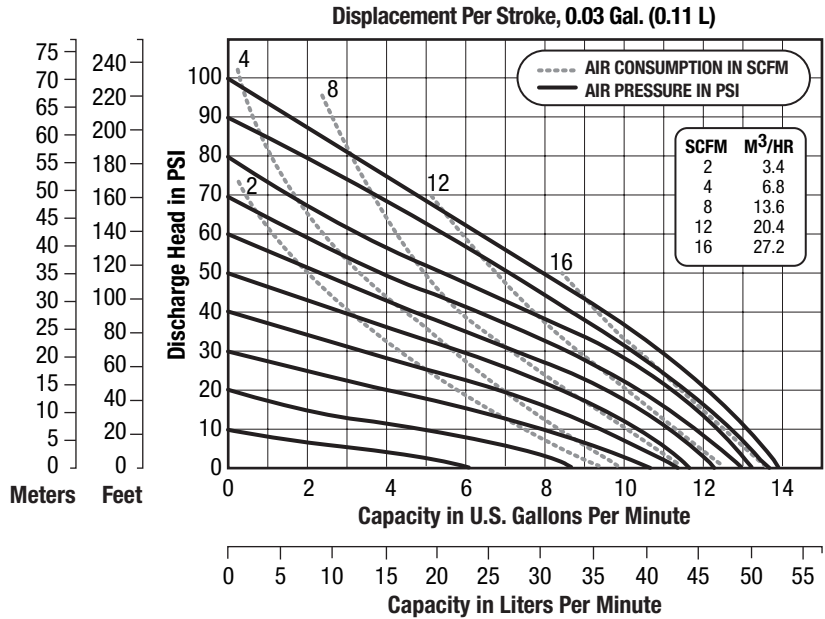

CAUTION: Do not exceed 100 psig (6.9 bars) air supply or liquid pressure.

DIMENSIONS

Consult factory for certified drawings.

E5

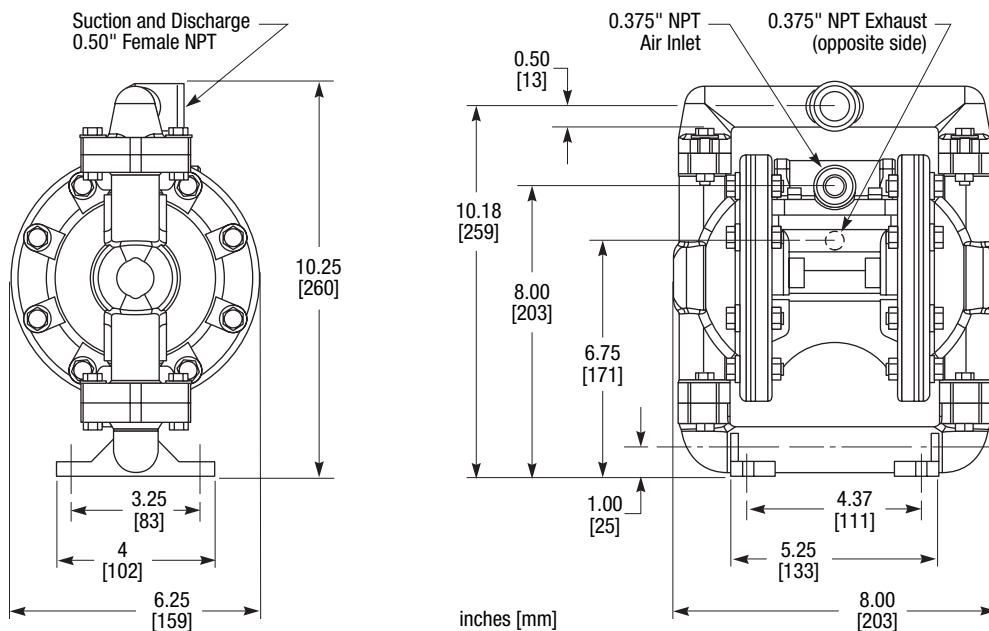

E5 1/2" Plastic Bolted Pumps Specifications and Performance

SPECIFICATIONS

E5

FLOW RATE (Adjustable) 0-14 gpm (53 lpm)

PORT SIZE

Inlet and Outlet..... 0.50" NPT

AIR INLET 0.375" NPT

AIR EXHAUST 0.375" NPT

SUCTION LIFT.. 15' Dry/25' Wet (6.096m/7.62m)

Teflon®..... 5' Dry/10' Wet (1.52m/3.048m)

MAX. PARTICLE SIZE (Dia.)0.0625"(1.6mm)

SHIPPING WEIGHTS

Polypropylene 10 lbs (4.54 kg)

Kynar® 10 lbs (4.54 kg)

Teflon® 12 lbs (5.45 kg)

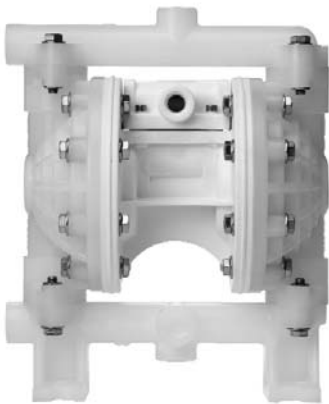

PERFORMANCE

Determined by actual flow meter tests.

E5

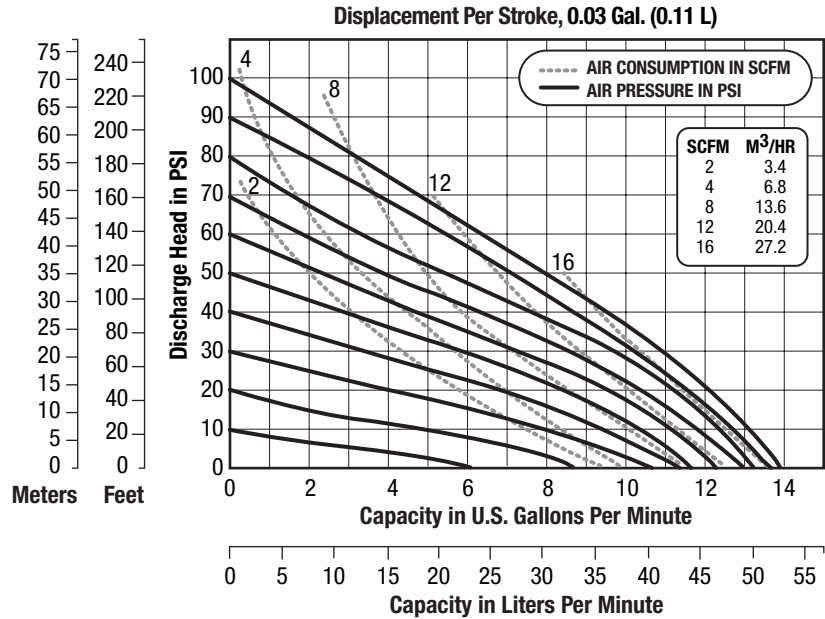

CAUTION: Do not exceed 100 psig (6.9 bars) air supply or liquid pressure.

DIMENSIONS

Consult factory for certified drawings.

E5

