

E3 3" Clamped Metallic Pumps Specifications and Performance

SPECIFICATIONS

E3

FLOW RATE (Adjustable) 0-260 gpm (984 lpm)
PORT SIZE
 Inlet and Outlet..... 3.0" NPT (BSP)
AIR INLET 0.5" NPT
AIR EXHAUST 1.0" NPT
SUCTION LIFT 20' Dry/25' Wet (6.10m/7.62m)
 Teflon®..... 10' Dry/20' Wet (3.05m/6.10m)
MAX. PARTICLE SIZE (Dia.) 0.375"(9.52mm)
SHIPPING WEIGHTS
 Aluminum 115 lbs (52.16 kg)
 Cast Iron, Stainless..... 210 lbs (95.25 kg)
 Hastelloy C..... 220 lbs (99.79 kg)



PERFORMANCE

Determined by actual flow meter tests.

E3

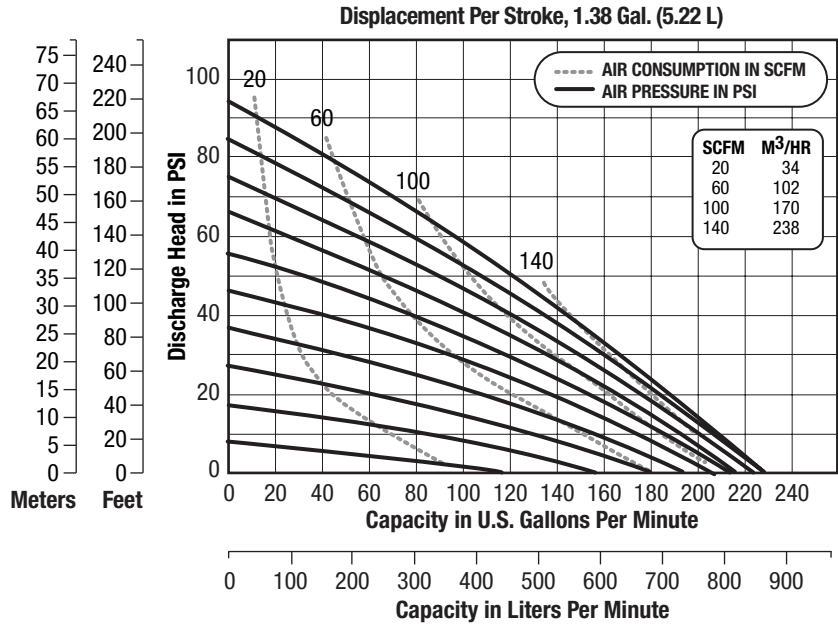

NOTE: For E3 pumps fitted with Teflon® diaphragms, reduce water discharge figures by 20%. Suction lift is reduced to 10' (3.05m) dry and 20' (6.10m) wet.

CAUTION: Do not exceed 125 psig (8.5 bars) air supply or liquid pressure.
Screen Mount Available For Aluminum Model.

DIMENSIONS

Consult factory for certified drawings.

E3

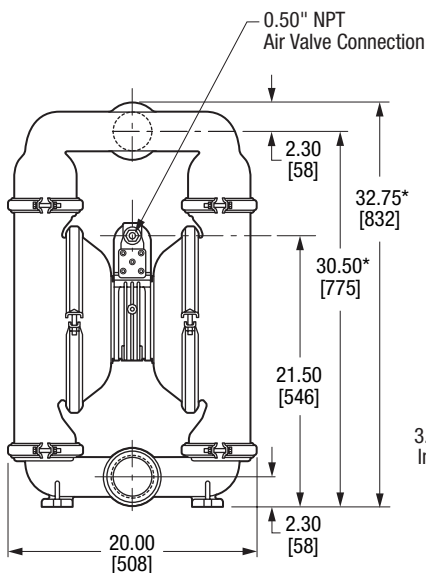

* Measurement is for Cast Iron pumps. Other materials of construction may be slightly smaller.

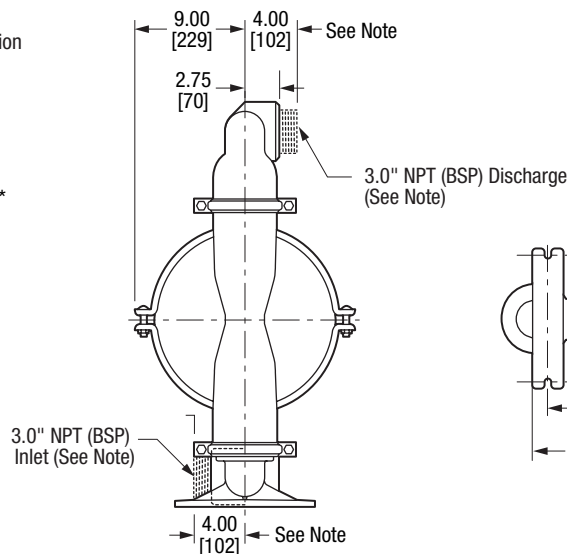

NOTE: Cast-in-Place Nipple, Aluminum Pump Only. Female threaded on others.

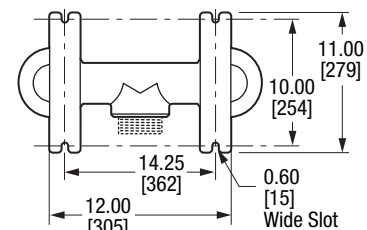

inches [mm]

E3 3" Bolted Metallic Pumps Specifications and Performance

SPECIFICATIONS

E3

FLOW RATE (Adjustable) 0-230 gpm (870 lpm)
PORT SIZE

Inlet and Outlet ... 3.0" ANSI, 150 lb class (DIN 80)

AIR INLET 0.50" NPT

AIR EXHAUST 1.0" NPT

SUCTION LIFT 20' Dry/25' Wet (6.09m/7.62m)

Teflon® 10' Dry/20' Wet (3.05m/6.09m)

MAX. PARTICLE SIZE (Dia.) 0.75" (19.1mm)

SHIPPING WEIGHTS

Aluminum 150 lbs (68 kg)

Stainless Steel 250 lbs (113 kg)

Hastelloy C 275 lbs (125 kg)



PERFORMANCE Determined by actual flow meter tests.

E3

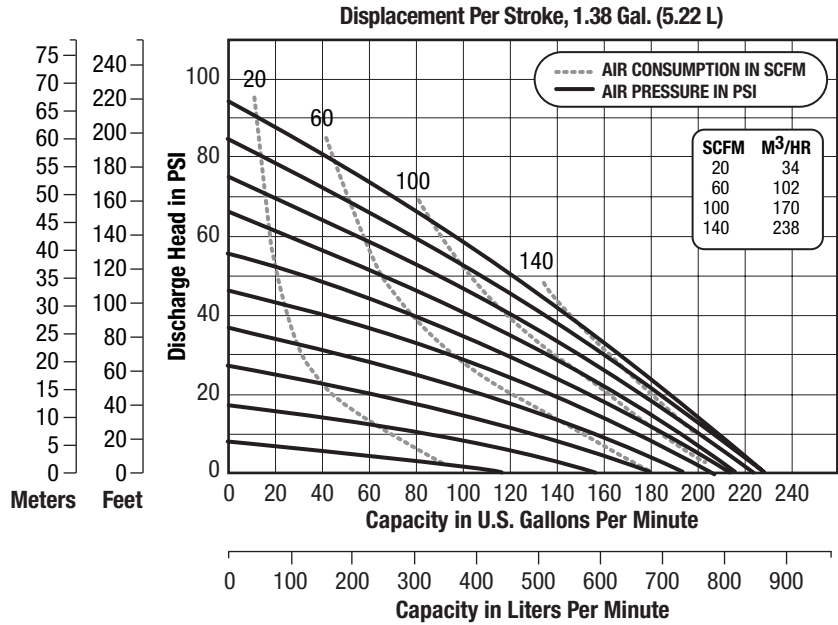

NOTE: For E3 pumps fitted with Teflon® diaphragms, reduce water discharge figures by 20%. Suction lift is reduced to 10' (3.05m) dry and 20' (6.10m) wet.

CAUTION: Do not exceed 125 psig (8.5 bars) air supply or liquid pressure.

DIMENSIONS Consult factory for certified drawings.

E3

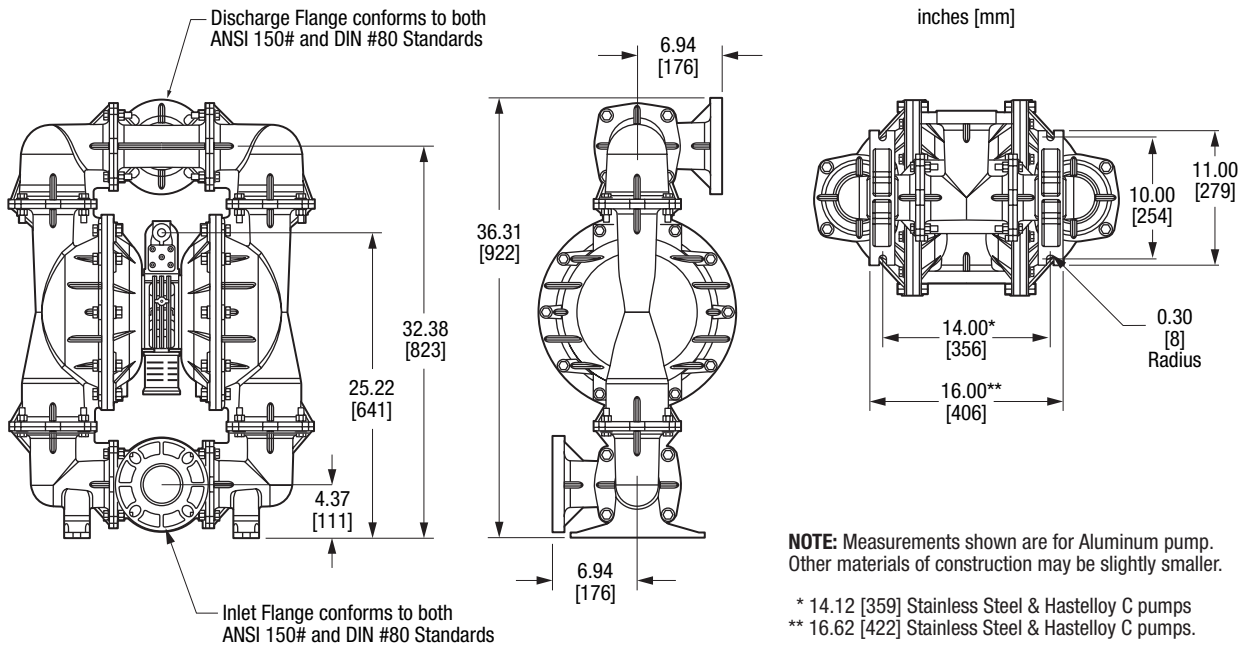

E3 3" Plastic Bolted Pumps Specifications and Performance

SPECIFICATIONS

E3

FLOW RATE (Adjustable) 0-238 gpm (901 lpm)
PORT SIZE
 Inlet and Outlet..... 3.0" ANSI or DIN 80 Flange
AIR INLET 0.75" NPTF
AIR EXHAUST 1.00" NPTF
SUCTION LIFT 20' Dry/25' Wet (6.10m/7.62m)
 Teflon®..... 10' Dry/20' Wet (3.05m/6.10m)
MAX. PARTICLE SIZE (Dia.) 0.71" (18mm)
SHIPPING WEIGHTS
 Polypropylene 231 lbs (105 kg)
 PVDF 315 lbs (143 kg)



PERFORMANCE

Determined by actual flow meter tests.

E3

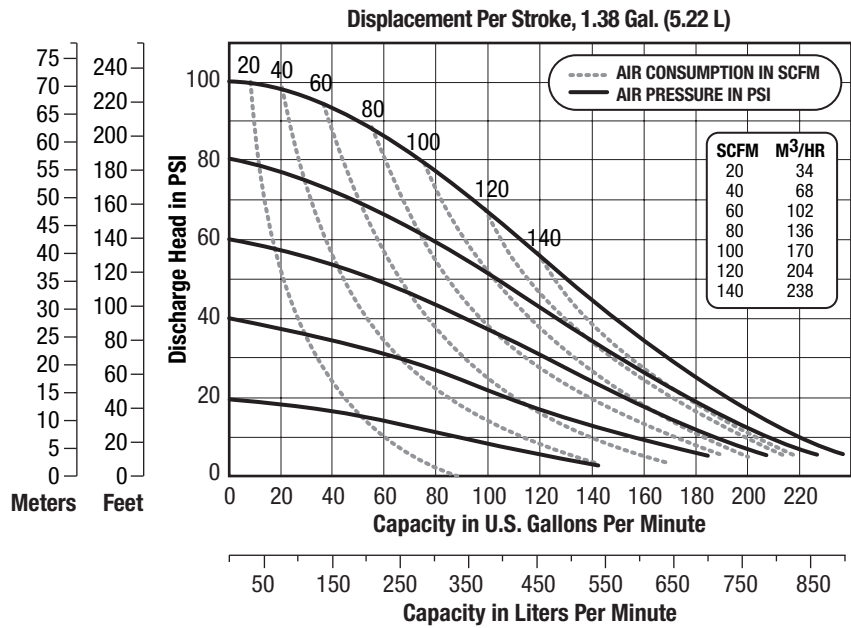

NOTE: For E3P pumps fitted with Teflon® diaphragms, reduce water discharge figures by 20%. Suction lift is reduced to 10' (3.05m) dry and 20' (6.10m) wet.

CAUTION: Do not exceed 125 psig (8.5 bars) air supply or liquid pressure.

DIMENSIONS

Consult factory for certified drawings.

E3

