

## 3/4" Bolted Metallic Pumps

E7

► Aluminum

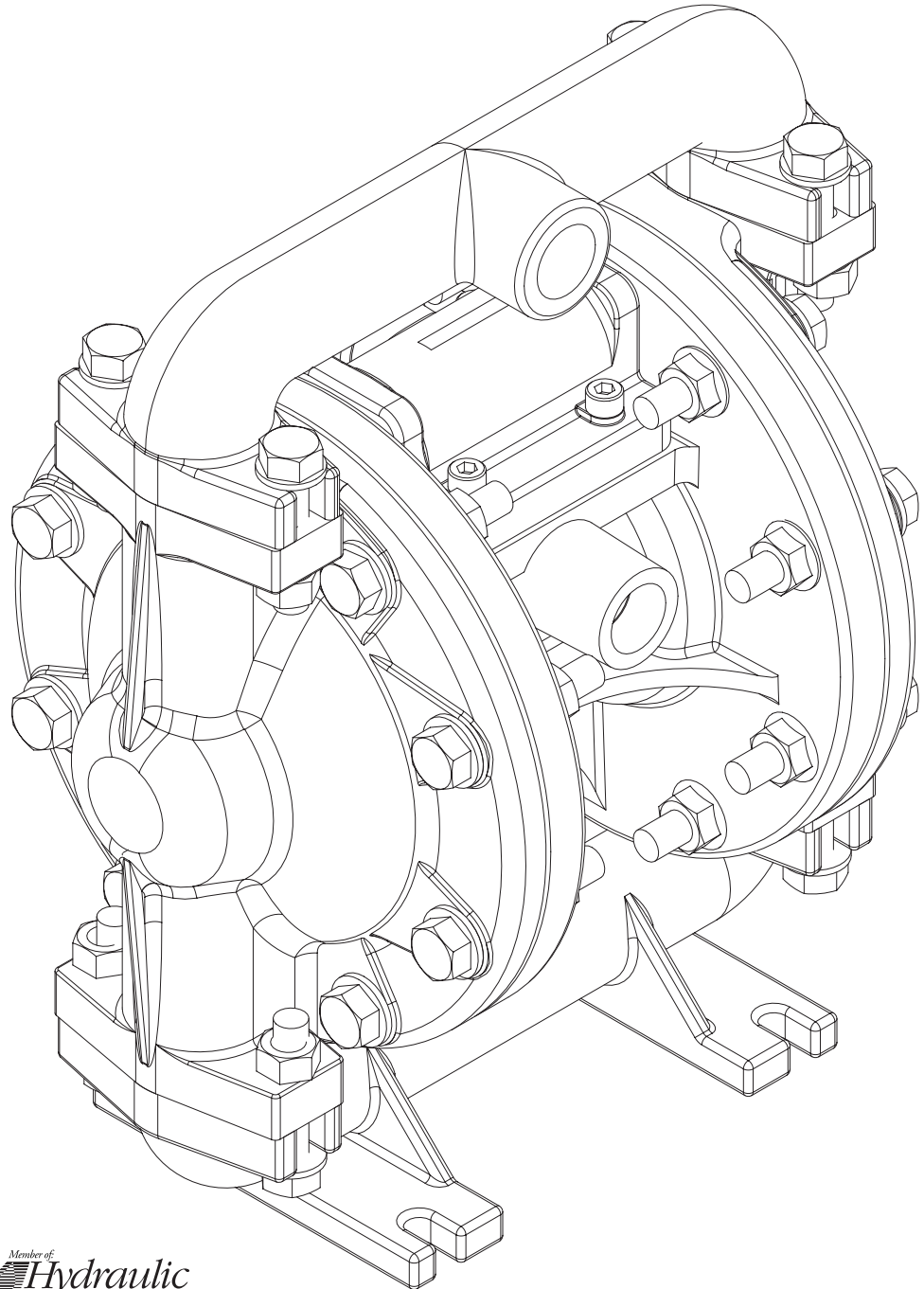

# SPECIFICATIONS AND PERFORMANCE

## Versa-Matic Model E7 3/4" Bolted Metallic Pump

### Flow Rate

Adjustable to . . . . . 0-14 gpm (53 lpm)

### Port Size

Suction . . . . . 1/2" NPTF

Discharge . . . . . 1/2" NPTF

Air Inlet . . . . . 3/8" NPT

Air Exhaust . . . . . 3/8" NPT

### Suction Lift

Rubber . . . . . 20' (6.09 m) Dry

PTFE . . . . . 5' (1.52 m) Dry

### Max. Particle Size (Diameter)

. . . . . 0.0625" (1.66 mm)

**dB(A) Reading** . . . . . 67.1 dB(A)

### Shipping Weights

Aluminum . . . . . 18 lbs (4.5 kg)

**Caution: do not exceed 125 psig  
(8.5 bar) liquid or air supply pressure.**

Displacement Per Stroke, 0.03 Gal. (0.11 L)

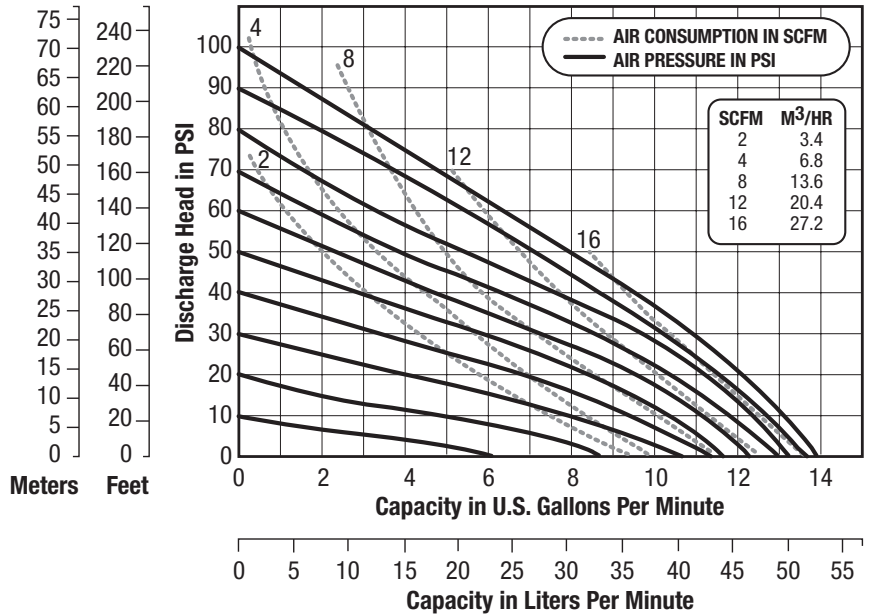

## E7 3/4" Bolted Metallic Pump

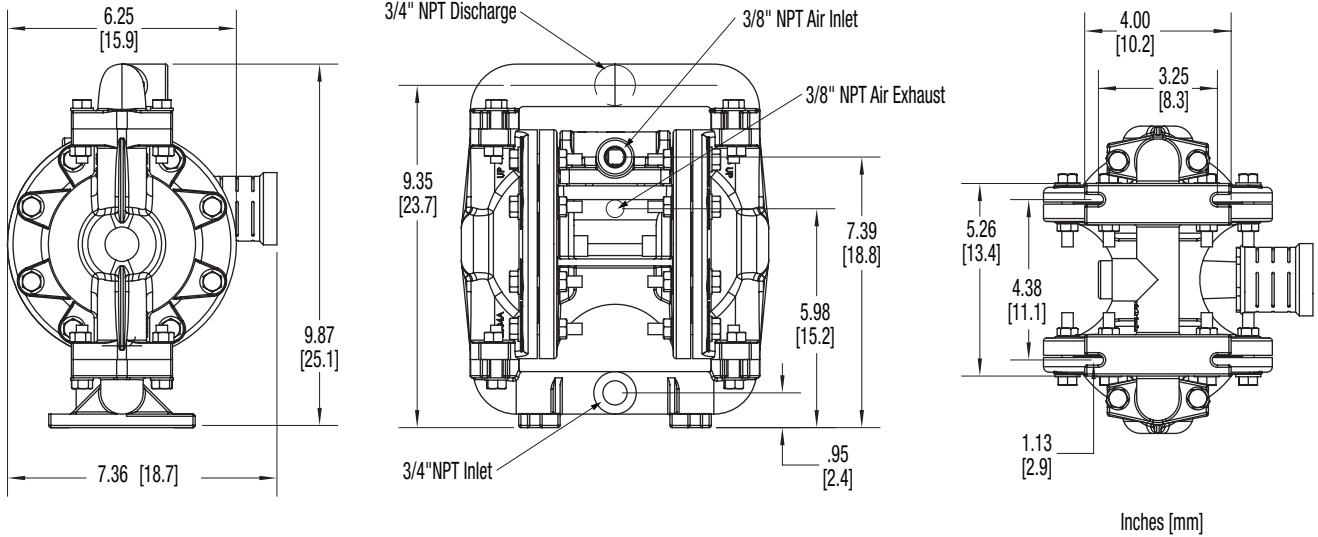

# SAFETY WARNINGS

**Read these instructions completely before installation and start-up. It is the responsibility of the purchaser to retain this manual for reference. Failure to comply with the recommendations stated in this manual could result in death, serious bodily injury and/or property damage including damage to the pump and/or voiding the factory warranty.**

**Correct pump selection** is crucial to the pump operation. Please assure pressure, temperature and chemical compatibility before installation. Please consult Versa-Matic Pump, Engineering Specifications, Chemical Compatibility Chart, or your distributor if in doubt about any application.

## **Operating Limitations for Various Elastomers**

Neoprene	0°F (-18°C) to 200°F (93°C)
Buna-N	10°F (-12°C) to 180°F (82°C)
Nordel	-60°F (-51°C) to 280°F (138°C)
Viton	-40°F (-40°C) to 350°F (176°C)
PTFE	40°F (4°C) to 220°F (105°C)
Polyurethane	10°F (-12°C) to 170°F (77°C)
XL TPE	-20°F (-29°C) to 300°F (149°C)
FDA Hytrel	-20°F (-29°C) to 220°F (104°C)

## **Operating Limitations for Plastic Pumps**

Kynar (PVDF)	10°F (-12°C) to 225°F (107°C)
Polypropylene	32°F (0°C) to 175°F (79°C)

**Maximum temperature limits** are based upon mechanical stress only. Certain chemicals and environment conditions significantly reduce maximum safe temperature limits.

**Before pump operation**, inspect all gasketed fasteners for looseness caused by gasket creep. Re-torque all loose fasteners to prevent leakage. Follow recommended torques

stated in this manual. Failure of the sealing components creates the possibility of jetting or forceful discharge of pumped material at a potentially harmful velocity.

**Be certain that approved eye protection and protective clothing** are always worn during installation, service, maintenance or when in the vicinity of the pump. Failure to follow these recommendations may result in serious injury or death.

**Never allow** the piping system to be supported by the pump manifolds or valve housing. The manifolds and valve housing are not designed to support any structural weight and failure of the pump may result.

**Take action to prevent static sparking.** Fire or explosion can result, especially when handling flammable liquids. The pump, piping, valves, containers, or other miscellaneous equipment must be grounded.

**Noise levels** can exceed 85 dBA. Take precautions to prevent personal injury due to excessive pump noise.

**Do not exceed** pump maximum operating pressure (found on label and/or operating manual.)

**Before doing any maintenance** or repair on this pump, be certain all pressure is completely vented for the pump, suction, discharge, piping, and all other openings.

**In the event of a diaphragm rupture**, pumped material may enter the air end of the pump and be discharged into the atmosphere. If pumping a product that is hazardous or toxic, the air exhaust must be piped to an appropriate area for safe disposition.

# INSTALLATION, OPERATION AND MAINTENANCE

## Installation

The pump should be mounted in a vertical position. In permanent installations, the pump should be attached to plant piping using a flexible coupling on both the intake and discharge connections to reduce vibration to the pump and piping. To further reduce vibration, a surge suppressor next to the pump may be used.

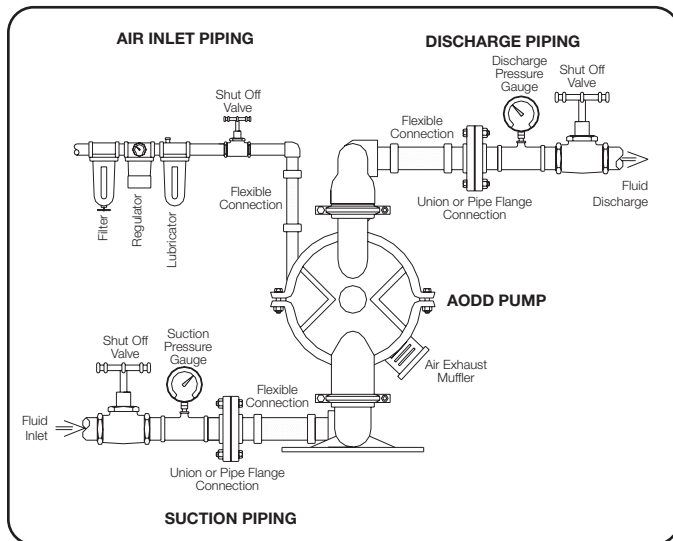

Suction pipe size should be at least the same diameter as the inlet connection size, even larger if highly viscous fluid is to be pumped. If suction hose is used, it must be of a non-collapsible reinforced type. Discharge piping should be of at least the same diameter as the discharge connection. It is critical,

especially on the suction side of the pump, that all fittings and connections are air tight or pumping efficiency will be reduced and priming will be difficult.

Make certain the air supply line and connections and compressor are capable of supplying the required pressure and volume of air to operate the pump at the desired flow rate. The quality of the compressed air source should be considered. Air that is contaminated with moisture and dirt may result in erratic pump performance and increased maintenance cost as well as frequent process “down time” when the pump fails to operate properly.

## Pump Operation

The pump is powered by compressed air. Compressed air is directed to the pump air chamber by the main air valve. The compressed air is separated from the fluid by a membrane called a diaphragm. The diaphragm in turn applies pressure on the fluid and forces it out of the pump discharge. While this is occurring, the opposite air chamber is de-pressurized and exhausted to atmosphere and fluid is drawn into the pump suction. The cycle again repeats, thus creating a constant reciprocating action which maintains flow through the pump. The flow is always in through the bottom suction connection and out through the top discharge connection. Since the air pressure acts directly on the diaphragms, the pressure applied to the fluid roughly approximates the air supply pressure supplied to the main air valve.

## Recommended Piping Connections

Pump Size	Minimum Air Line Size	Minimum Suction Line Size
1/2"	1/2"	1/2"
3/4"	1/2"	3/4"
1"	1/2"	1"
1-1/2"	1/2"	1-1/2"
2"	1/2"	2"
3"	3/4"	3"

## E7 Bolted Pump Torque Settings

Manifold Bolts	230 in-lbs (26.0 N-m)
Water Chamber Bolts	100 in-lbs (11.3 N-m)
Diaphragm Plates — Rubber	75 in-lbs (8.5 N-m)
Diaphragm Plates — PTFE	75 in-lbs (8.5 N-m)
Air Valve Cap Screws	30 in-lbs (3.4 N-m)

## Elastomer Suffix Codes

Suffix Code	Material
A	Acetal
BN	Buna-N, Nitrile
N	Neoprene
ND	Nordel, EPDM
TF	PTFE
FG	Hytrel
XL	XL, Santoprene
VT	Viton
TX	Bonded PTFE

# PARTS LIST

## AIR VALVE ASSEMBLY

		Standard: Polypropylene		Optional: Aluminum	
Item	Description	Qty.	Part #	Part #	Part #
	Air Valve Assembly (Includes items 1-10)		E500		E500-ATEX
1	Valve Body	1	E500A		E500A-ATEX
2	Valve Spool	1	E500B ASY		E500B ASY
3	Valve Spool U-Cup	2	P98-104A		P98-104A
4	End Cap	2	E500D ASY		E500D-ATEX
5	End Cap O-Ring	2	E500E		E500E
6	Staple	2	E500F		E500F
7	Air Diverter	1	E500G		E500G
8	Valve Insert	1	E500H		E500H
9	Valve Gasket	1	E500J		E500J
10	Valve Screw	4	P24-208		P24-208

## AIR END ASSEMBLY

		Standard: Polypropylene		Optional: Aluminum	
Item	Description	Qty.	Part #	Part #	Part #
11	Center Section	1	E501A		E501A-SC
18	Pilot Shaft	1	E503A		E503A
19	Pilot Shaft Spacer	5	E503C		E503C
20	Pilot Shaft O-Ring	6	E503B		E503B
21	Pilot Shaft Snap Ring	2	E503D		E503D
22	Shaft Retainer	2	E501B		E501B
25	Shaft Retainer Screw	4	E501C		E501C
33	Muffler	1	VTM-3		VTM-3

## DIAPHRAGM ASSEMBLY

		TPE		PTFE Bonded		PTFE 2-Piece	
Item	Description	Qty.	Part #	Part #	Part #	Part #	Part #
34	Main Shaft O-Ring	2	E502B	E502B		E502B	E502B
35	Main Shaft	1	E502A	E502A		E502A	E502A
37	Inner Diaphragm Plate	2	V199	V199		V199	V199
38	Outer Diaphragm Plate	2	SV199B	SV199B		SV199B	SV199B
40	Diaphragm	2	E505BN E505VT E505XL E505ND E505N E505FG	E505TX		E505TF	E505TF
41	Back-Up Diaphragm	2	N/A	N/A		E505N	E505N

## WET END ASSEMBLY

Item	Description	Qty.	Part #
44	Water Chamber	2	E504A
45	Water Chamber Bolt	16	SV189D
46	Water Chamber Washer	16	SV189C
47	Water Chamber Nut	16	SV185B
49	Valve Seat O-ring	4	V111BN, V111HT, V111ND, V111TES, V111TEV, V111VT, V111XL
50	Valve Seat	4	V110A
52	Valve Ball	4	V111A, V111BN, V111FG, V111SS, V111TF, V111VT, V111SL
53	Discharge Manifold	1	V196A
54	Inlet Manifold	1	V197A
63	Manifold Bolts	8	SV197F
64	Manifold Washers	8	SV196C
65	Manifold Nuts	8	SV197E

# EXPLODED VIEWS

Exploded View shows Rugged Diaphragm

## PTFE Diaphragms

