

3/4" Bolted Metallic Pumps

Aluminum Air Section Available



Specifications

Flow Rate adjustable to . . . 0-14 gpm (53 lpm)

Port Size

Inlet and Discharge 0.75" NPT

Air Inlet 0.375" NPT

Air Exhaust 0.375" NPT

Suction Lift . . . 15' Dry/25' Wet (6.096m/7.62m)

Teflon® 5' Dry/10' Wet (1.52m/3.048m)

Max. Particle Size (Dia.) 0.0625" (1.6mm)

Shipping Weights

Aluminum 15 lbs (6.80 kg)

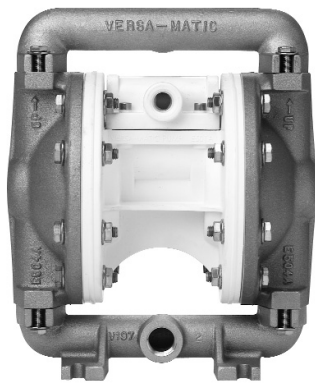

Performance

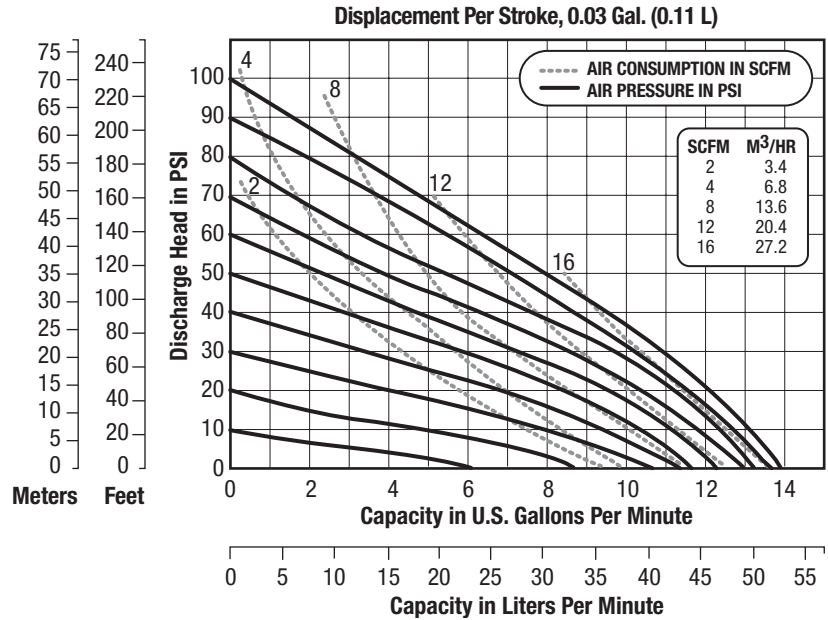

CAUTION: Do not exceed 100 psig (6.9 bars) air supply or liquid pressure.

Dimensions

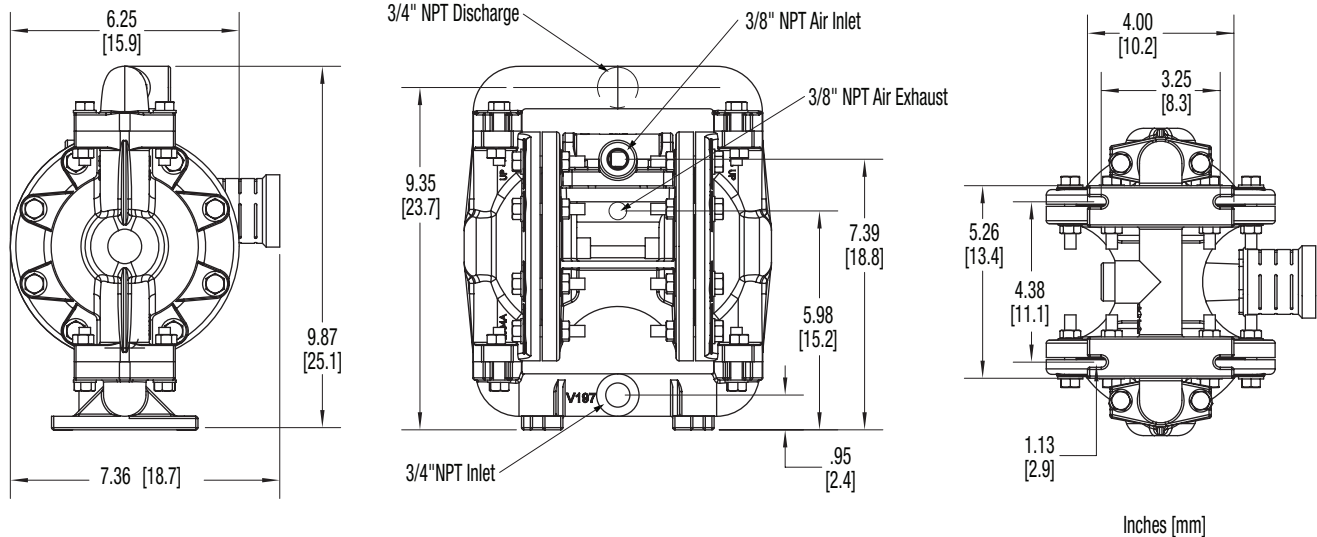

Consult factory for certified drawings.